

Write your name here

Surname

Other names

**Pearson Edexcel**  
**Level 1/Level 2 GCSE (9 - 1)**

Centre Number

--	--	--	--	--

Candidate Number

--	--	--	--

# Mathematics

## Paper 3 (Calculator)

**Higher Tier**

Sample Assessment Materials – Issue 2

**Time: 1 hour 30 minutes**

Paper Reference

**1MA1/3H**

**You must have:** Ruler graduated in centimetres and millimetres, protractor, pair of compasses, pen, HB pencil, eraser, calculator.

Total Marks

### Instructions

- Use **black** ink or ball-point pen.
- **Fill in the boxes** at the top of this page with your name, centre number and candidate number.
- Answer **all** questions.
- Answer the questions in the spaces provided – *there may be more space than you need.*
- **Calculators may be used.**
- If your calculator does not have a  $\pi$  button, take the value of  $\pi$  to be 3.142 unless the question instructs otherwise.
- Diagrams are **NOT** accurately drawn, unless otherwise indicated.
- You must **show all your working out.**



### Information

- The total mark for this paper is 80
- The marks for **each** question are shown in brackets – *use this as a guide as to how much time to spend on each question.*

### Advice

- Read each question carefully before you start to answer it.
- Keep an eye on the time.
- Try to answer every question.
- Check your answers if you have time at the end.

Turn over ►

S48576A

©2015 Pearson Education Ltd.

6/4/17/14/6/6/6/



**PEARSON**

Answer ALL questions.

Write your answers in the spaces provided.

You must write down all the stages in your working.

- 1 The diagram shows a trapezium  $ABCD$  and two identical semicircles.

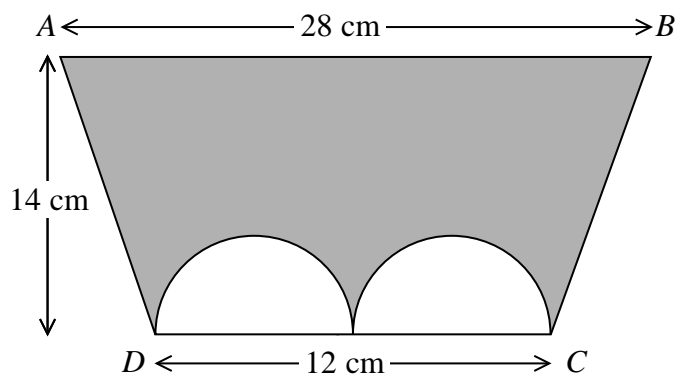

The centre of each semicircle is on  $DC$ .

Work out the area of the shaded region.

Give your answer correct to 3 significant figures.

..... cm<sup>2</sup>

(Total for Question 1 is 4 marks)

DO NOT WRITE IN THIS AREA

2 Asif is going on holiday to Turkey.

The exchange rate is  $\text{£}1 = 3.5601$  lira.

Asif changes  $\text{£}550$  to lira.

- (a) Work out how many lira he should get.  
Give your answer to the nearest lira.

..... lira  
(2)

Asif sees a pair of shoes in Turkey.  
The shoes cost 210 lira.

Asif does not have a calculator.  
He uses  $\text{£}2 = 7$  lira to work out the approximate cost of the shoes in pounds.

- (b) Use  $\text{£}2 = 7$  lira to show that the approximate cost of the shoes is  $\text{£}60$

(2)

- (c) Is using  $\text{£}2 = 7$  lira instead of using  $\text{£}1 = 3.5601$  lira a sensible start to Asif's method to work out the cost of the shoes in pounds?

You must give a reason for your answer.

.....  
.....  
(1)

**(Total for Question 2 is 5 marks)**

3 Here are the first six terms of a Fibonacci sequence.

1 1 2 3 5 8

The rule to continue a Fibonacci sequence is,

the next term in the sequence is the sum of the two previous terms.

(a) Find the 9th term of this sequence.

.....  
(1)

The first three terms of a different Fibonacci sequence are

$a$   $b$   $a + b$

(b) Show that the 6th term of this sequence is  $3a + 5b$

(2)

Given that the 3rd term is 7 and the 6th term is 29,

(c) find the value of  $a$  and the value of  $b$ .

.....  
(3)

**(Total for Question 3 is 6 marks)**

- 4 In a survey, the outside temperature and the number of units of electricity used for heating were recorded for ten homes.

The scatter diagram shows this information.

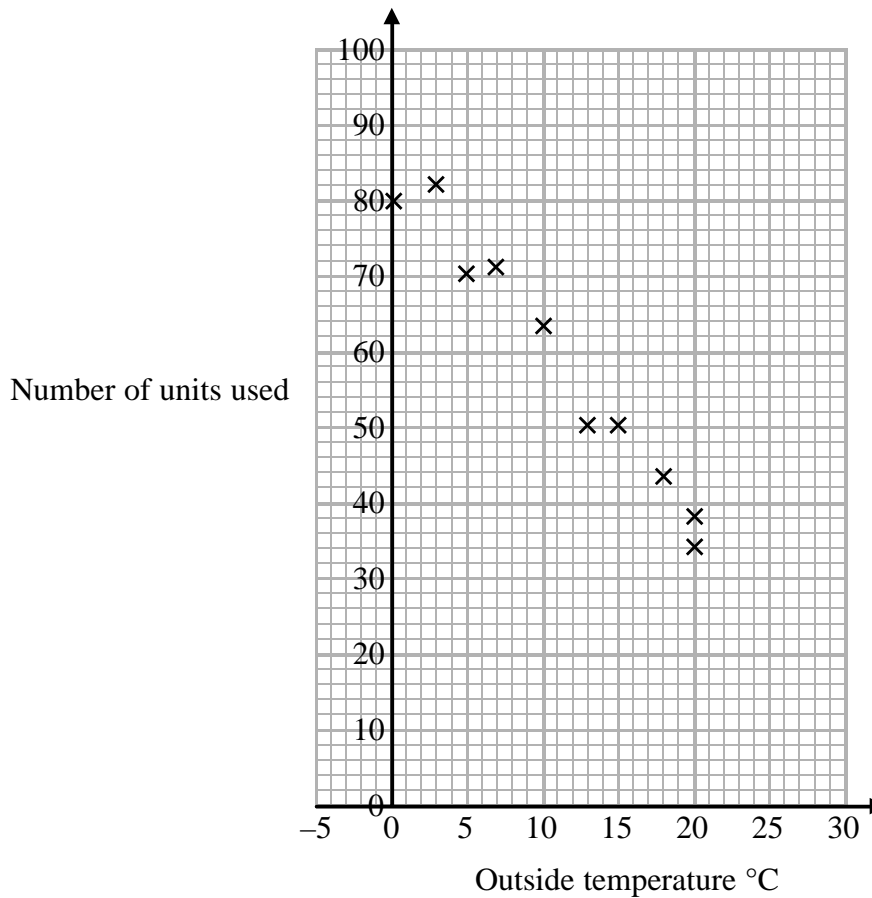

Molly says,

“On average the number of units of electricity used for heating decreases by 4 units for each °C increase in outside temperature.”

- (a) Is Molly right?  
Show how you get your answer.

(3)

- (b) You should **not** use a line of best fit to predict the number of units of electricity used for heating when the outside temperature is 30 °C.

Give one reason why.

(1)

(Total for Question 4 is 4 marks)

5 Henry is thinking of having a water meter.

These are the two ways he can pay for the water he uses.

**Water Meter**

A charge of £28.20 per year

**plus**

91.22p for every cubic metre of water used

1 cubic metre = 1000 litres

**No Water Meter**

A charge of £107 per year

Henry uses an average of 180 litres of water each day.

Use this information to determine whether or not Henry should have a water meter.

**(Total for Question 5 is 5 marks)**

DO NOT WRITE IN THIS AREA

DO NOT WRITE IN THIS AREA

DO NOT WRITE IN THIS AREA

DO NOT WRITE IN THIS AREA

6 Liz buys packets of coloured buttons.

There are 8 red buttons in each packet of red buttons.  
There are 6 silver buttons in each packet of silver buttons.  
There are 5 gold buttons in each packet of gold buttons.

Liz buys equal numbers of red buttons, silver buttons and gold buttons.

How many packets of each colour of buttons did Liz buy?

.....packets of red buttons

.....packets of silver buttons

.....packets of gold buttons

**(Total for Question 6 is 3 marks)**

7 The cumulative frequency table shows the marks some students got in a test.

Mark ( $m$ )	Cumulative frequency
$0 < m \leq 10$	8
$0 < m \leq 20$	23
$0 < m \leq 30$	48
$0 < m \leq 40$	65
$0 < m \leq 50$	74
$0 < m \leq 60$	80

(a) On the grid, plot a cumulative frequency graph for this information.

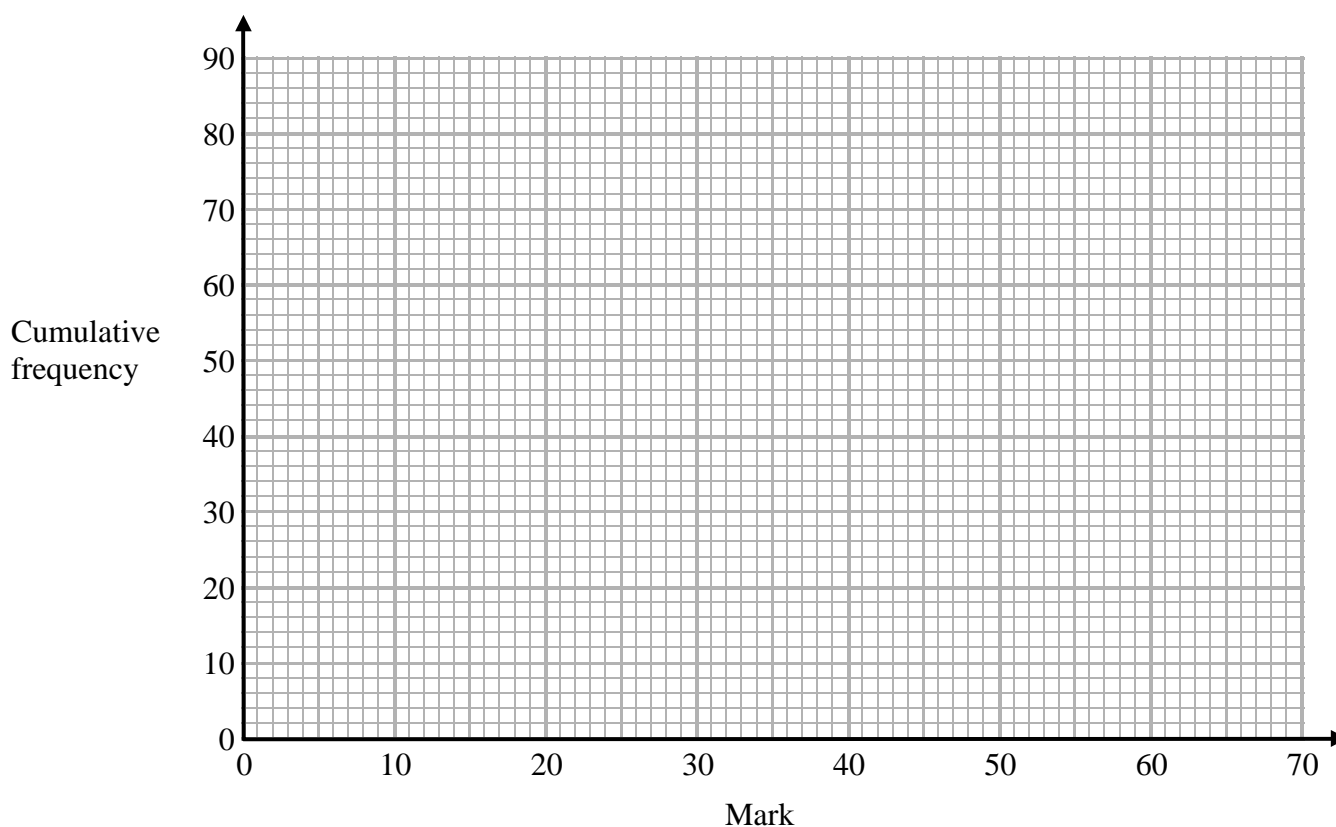

(2)

(b) Find the median mark.

(1)



DO NOT WRITE IN THIS AREA

Students either pass the test or fail the test.

The pass mark is set so that 3 times as many students fail the test as pass the test.

(c) Find an estimate for the lowest possible pass mark.

.....  
(3)

**(Total for Question 7 is 6 marks)**

---

**8** Write 0.000068 in standard form.

.....  
**(Total for Question 8 is 1 mark)**

---

9 (a) Factorise  $y^2 + 7y + 6$

.....  
(2)

(b) Solve  $6x + 4 > x + 17$

.....  
(2)

(c)  $n$  is an integer with  $-5 < 2n \leq 6$

Write down all the values of  $n$

.....  
(2)

**(Total for Question 9 is 6 marks)**

10 The function  $f$  is such that

$$f(x) = 4x - 1$$

(a) Find  $f^{-1}(x)$

$$f^{-1}(x) = \dots\dots\dots$$

(2)

The function  $g$  is such that

$$g(x) = kx^2 \text{ where } k \text{ is a constant.}$$

Given that  $fg(2) = 12$

(b) work out the value of  $k$

$$k = \dots\dots\dots$$

(2)

**(Total for Question 10 is 4 marks)**

**11** Solve  $x^2 - 5x + 3 = 0$

Give your solutions correct to 3 significant figures.

.....  
**(Total for Question 11 is 3 marks)**

---

DO NOT WRITE IN THIS AREA

12 Sami asked 50 people which drinks they liked from tea, coffee and milk.

All 50 people like at least one of the drinks

19 people like all three drinks.

16 people like tea and coffee but do **not** like milk.

21 people like coffee and milk.

24 people like tea and milk.

40 people like coffee.

1 person likes only milk.

Sami selects at random one of the 50 people.

(a) Work out the probability that this person likes tea.

.....  
(4)

(b) Given that the person selected at random from the 50 people likes tea, find the probability that this person also likes exactly one other drink.

.....  
(2)

(Total for Question 12 is 6 marks)

---

13  $ABCD$  is a rhombus.

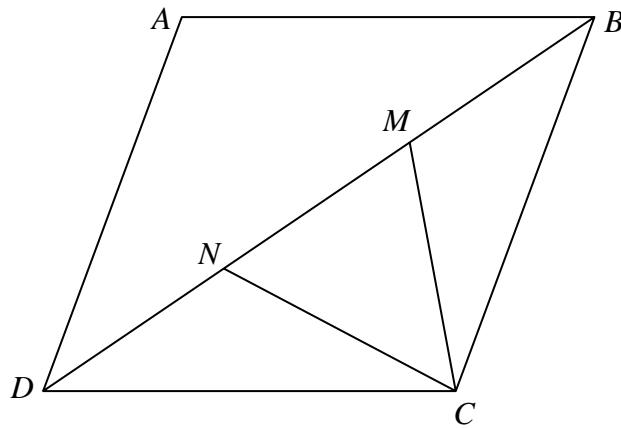

$M$  and  $N$  are points on  $BD$  such that  $DN = MB$ .

Prove that triangle  $DNC$  is congruent to triangle  $BMC$ .

(Total for Question 13 is 3 marks)

14 (a) Show that the equation  $x^3 + 4x = 1$  has a solution between  $x = 0$  and  $x = 1$

(2)

(b) Show that the equation  $x^3 + 4x = 1$  can be arranged to give  $x = \frac{1}{4} - \frac{x^3}{4}$

(1)

(c) Starting with  $x_0 = 0$ , use the iteration formula  $x_{n+1} = \frac{1}{4} - \frac{x_n^3}{4}$  twice, to find an estimate for the solution of  $x^3 + 4x = 1$

(3)

(Total for Question 14 is 6 marks)

DO NOT WRITE IN THIS AREA

15 There are 17 men and 26 women in a choir.  
The choir is going to sing at a concert.

One of the men and one of the women are going to be chosen to make a pair to sing the first song.

(a) Work out the number of different pairs that can be chosen.

.....  
(2)

Two of the men are to be chosen to make a pair to sing the second song.

Ben thinks the number of different pairs that can be chosen is 136

Mark thinks the number of different pairs that can be chosen is 272

(b) Who is correct, Ben or Mark?  
Give a reason for your answer.

.....  
.....  
(1)

**(Total for Question 15 is 3 marks)**

16  $VABCD$  is a solid pyramid.

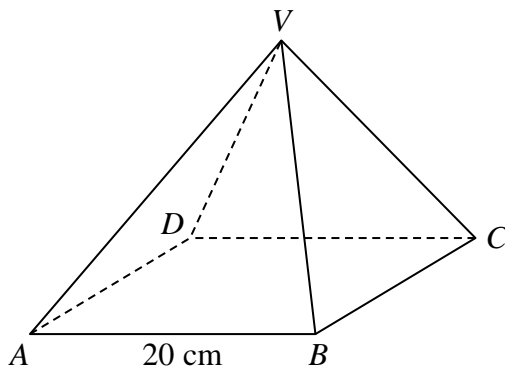

$ABCD$  is a square of side 20 cm.

The angle between any sloping edge and the plane  $ABCD$  is  $55^\circ$

Calculate the surface area of the pyramid.

Give your answer correct to 2 significant figures.

.....cm<sup>2</sup>

(Total for Question 16 is 5 marks)

DO NOT WRITE IN THIS AREA

DO NOT WRITE IN THIS AREA

DO NOT WRITE IN THIS AREA



DO NOT WRITE IN THIS AREA

17 Louis and Robert are investigating the growth in the population of a type of bacteria. They have two flasks A and B.

At the start of day 1, there are 1000 bacteria in flask A.  
The population of bacteria grows exponentially at the rate of 50% per day.

(a) Show that the population of bacteria in flask A at the start of each day forms a geometric progression.

(2)

The population of bacteria in flask A at the start of the 10th day is  $k$  times the population of bacteria in flask A at the start of the 6th day.

(b) Find the value of  $k$ .

.....  
(2)

At the start of day 1 there are 1000 bacteria in flask B.  
The population of bacteria in flask B grows exponentially at the rate of 30% per day.

(c) Sketch a graph to compare the size of the population of bacteria in flask A and in flask B.

(1)

**(Total for Question 17 is 5 marks)**

18

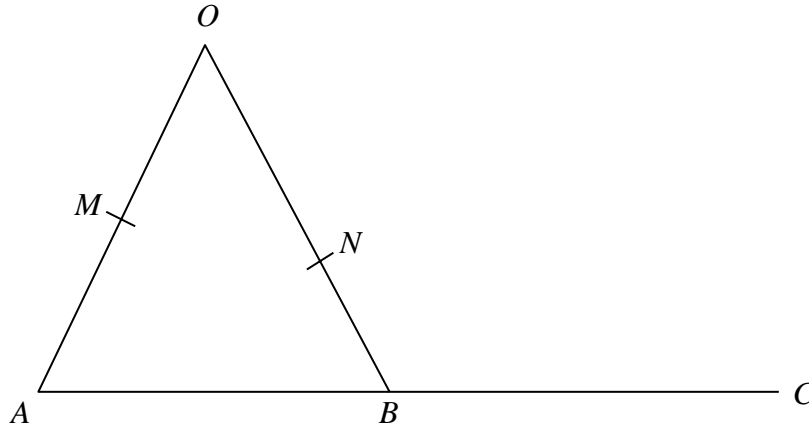

$OMA$ ,  $ONB$  and  $ABC$  are straight lines.

$M$  is the midpoint of  $OA$ .

$B$  is the midpoint of  $AC$ .

$\vec{OA} = 6\mathbf{a}$      $\vec{OB} = 6\mathbf{b}$      $\vec{ON} = k\mathbf{b}$  where  $k$  is a scalar quantity.

Given that  $MNC$  is a straight line, find the value of  $k$ .

(Total for Question 18 is 5 marks)

**TOTAL FOR PAPER IS 80 MARKS**